

Name _____

FOM 3 Unit 6: Circles

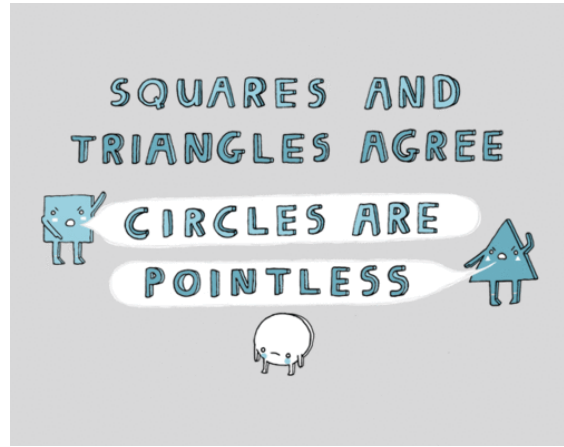

Monday	Tuesday	Wednesday	Thursday	Friday
		November 7 <ul style="list-style-type: none">• Arcs and angles of circles HW: worksheet 6.1	November 8 <ul style="list-style-type: none">• Lengths with circles HW: worksheet 6.2	November 9 <ul style="list-style-type: none">• QUIZ!!• Equation of a circle HW: worksheet 6.3
November 12 <ul style="list-style-type: none">• No school - Veterans Day	November 13 <ul style="list-style-type: none">• Equation of a circle with completing the square HW: worksheet 6.4	November 14 <ul style="list-style-type: none">• Arc length and area of sector HW: worksheet 6.5	November 15 <ul style="list-style-type: none">• Review HW: finish review	November 16 <ul style="list-style-type: none">• TEST!!

6.1 - Arcs and Angles Formed by Secants, Tangents, and Chord

Determine the value of x .

1

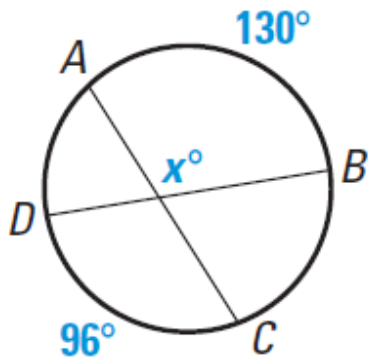

2

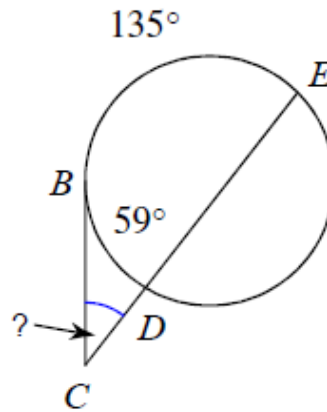

3

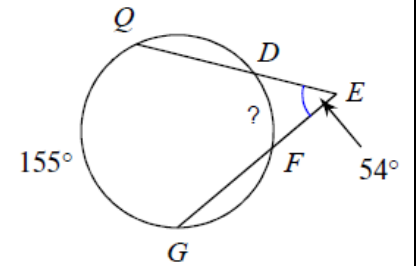

4

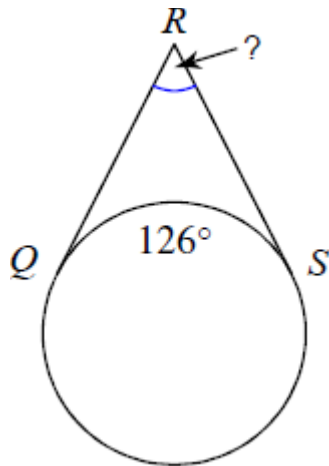

5

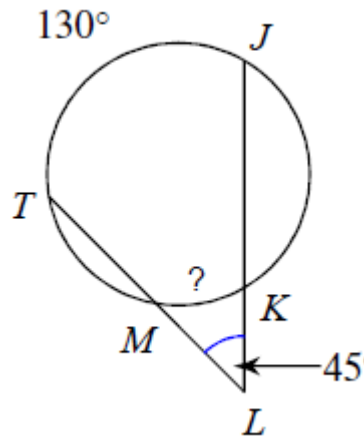

6

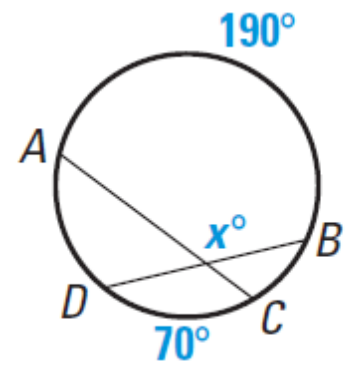

7

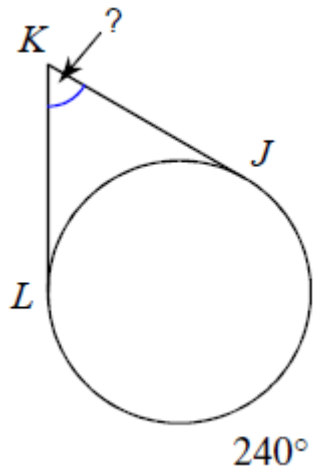

8

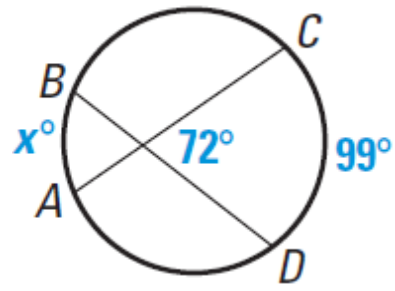

9

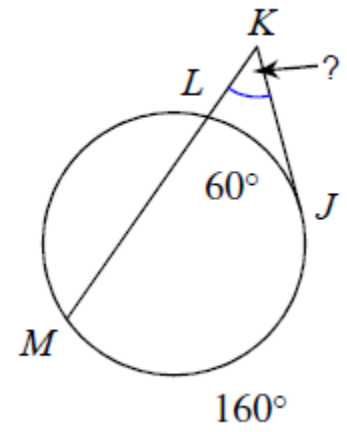

10

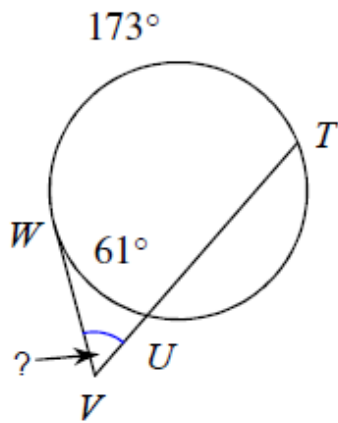

11

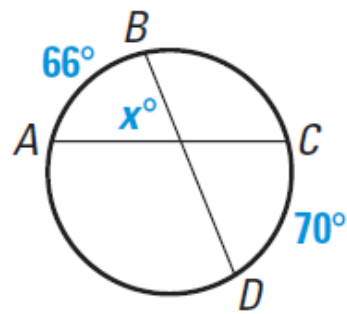

12

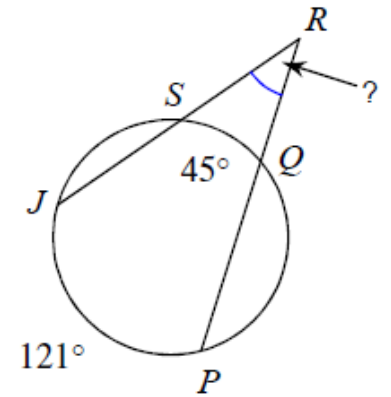

6.2 - Lengths with Secants, Tangents, Chords, and Radii

Determine the value of x .

1

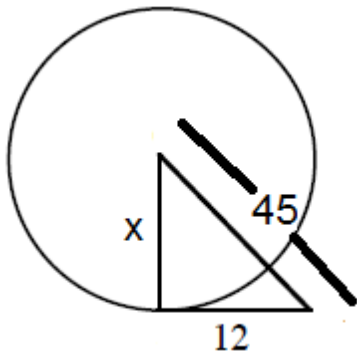

2

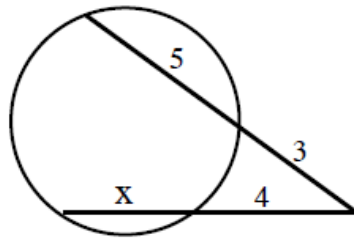

3

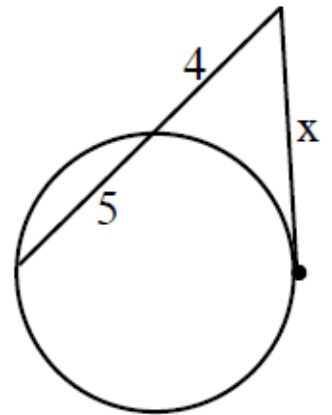

4

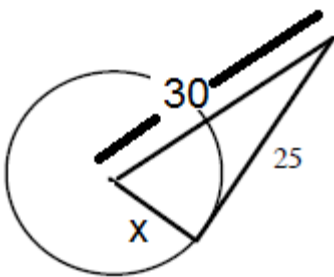

5

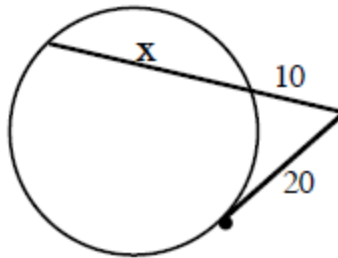

6

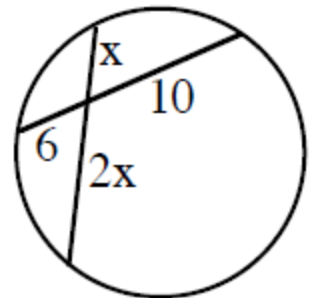

7

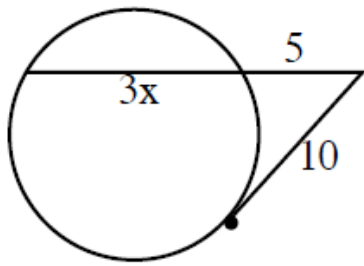

8

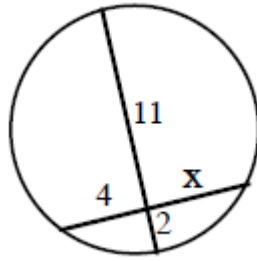

9

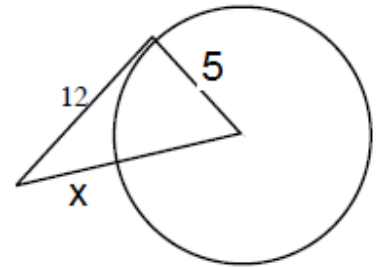

10

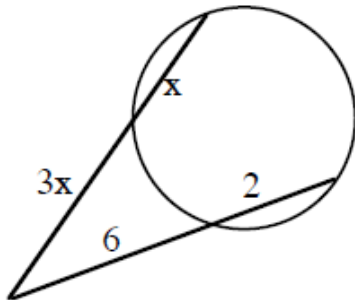

11

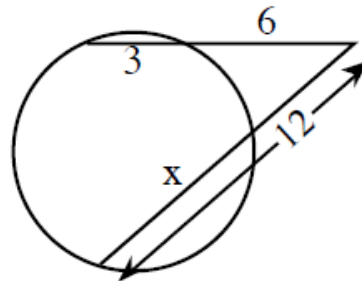

12

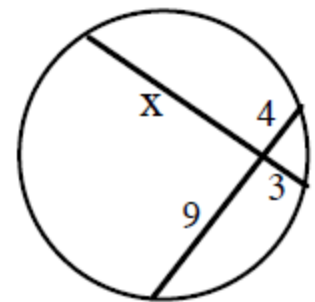

6.3 - Equation of a Circle

Write the equation of the circle with the given information.

1. center: $(4, -8)$
radius: 5

2. center: $(-3, -2)$
radius: 2

3. center: $(5, 10)$
radius: 4

4. center: origin
radius: 12

5. center: $(-11, 8)$
radius: 1

6. center: $(0, 12)$
radius: 14

Determine the center and radius of each circle. The graph the circle.

7. Graph: $(x - 1)^2 + (y + 3)^2 = 4$

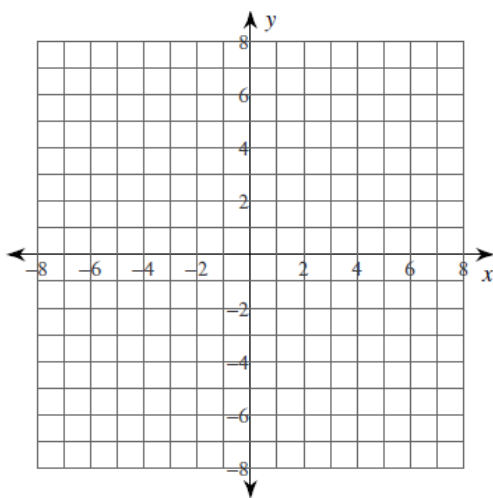

8. Graph: $(x + 2)^2 + (y - 1)^2 = 16$

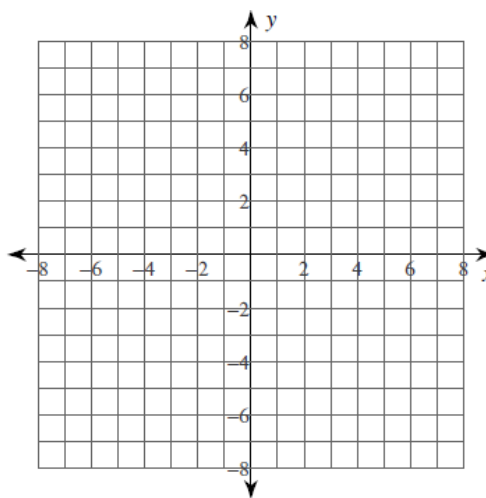

9. Graph: $(x - 1)^2 + (y - 4)^2 = 9$

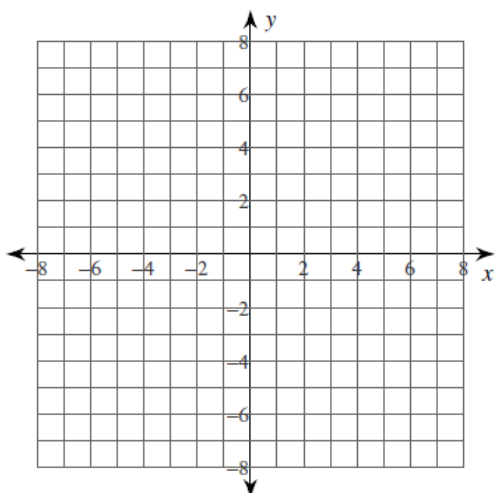

10. Graph: $x^2 + (y - 3)^2 = 1$

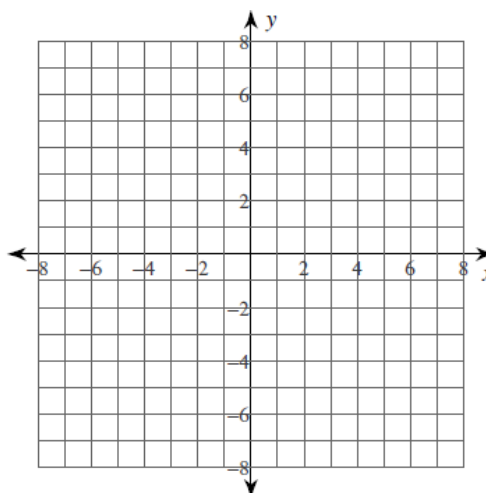

6.4 - Equation of a Circle with Completing the Square

Determine the equation of the circle in standard form. Then determine the center and radius of the circle.

1. $x^2 + y^2 + 4x - 16y + 52 = 0$

2. $x^2 + y^2 + 2x + 18y + 1 = 0$

3. $x^2 + y^2 - 14x - 2y - 50 = 0$

4. $x^2 + y^2 - 10x + 10y + 48 = 0$

5. $x^2 + y^2 + 18x + 17 = 0$

6. $x^2 + y^2 + 6x - 12y + 18 = 0$

6.5 - Arc Length and Area of a Sector

1. radius = 7 ft, central angle = 18°
Find arc length.

2. radius = 2 in, central angle 240°
Find area of sector.

3. area of sector = 30π in², radius = 6 in
Find central angle

4. area of sector = 116π cm², central angle = 110°
Find diameter.

5. central angles = 130° , arc length = 14 cm
Find radius.

6. arc length = 8π cm, radius = 20 cm
Find central angle.

7. Determine the arc length.

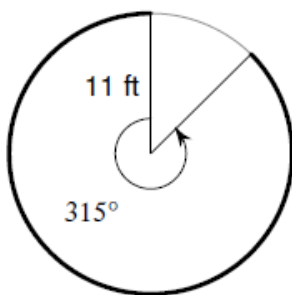

8. Determine the area of sector.

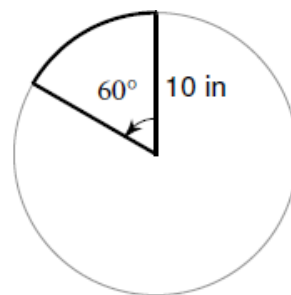

9. Determine the area of sector.

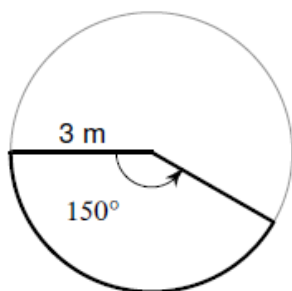

10. Determine the arc length.

